

MOGENSEN-F - an efficient and compact solution



- Mogensen -F with dual motors.



- Modularised 0,5 m wide rear covers with 2 quick-release fasteners.



- Screen cloth tensioning with electronic remote supervision.



- Frame with vibration-dampening springs



- Strategically positioned inspection ports simplify screen cloth change.



The Mogensen-F is an efficient and flexible long decked Sizer that combines Divergators/Bar Sizers coarse sorting with the screen cloths' fine sorting. Together or separately.

It has a very robust and compact construction, large accessibility, simply maintenance and low power requirement. The linear vibrator movement enables careful and efficient screening.

Mogensen-F consists of a base module with feed inlet, vibrators and compression spring suspension. A range of different units can be attached to the base module, depending upon the duty.

It can be supplied in widths 1, 1.5 m and 2 m and it is supplied on a support frame which simplifies transportation, installation and start-up. Other accessories are electrical control units for control of vibrators and several systems for wear protection and mesh cleaning.

A flexible range of Sizers

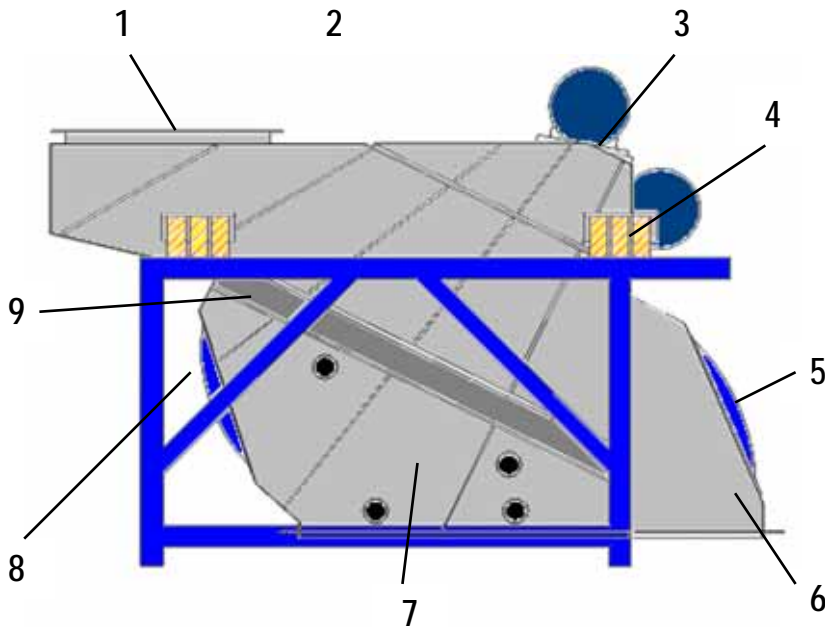

1. Large material inlet
2. Screen frame with large volume
3. Vibrator unit
4. Spring package
5. Dust guard dismantable at inspection
6. Front system with many different variations
7. Screen unit with short or long screen cloths
8. Dust guard dismantable at changing of screen cloth
9. Intermediate with Divergators/Bar Sizers alternatively long screen cloth



The picture shows the upper screening deck with Divergators/Bar Sizers

- Large capacity
- High screening efficiency
- Compact and lightweight
- Low Power requirement
- Robust and reliable construction
- Wide range of accessories
- Maintenance-friendly
- Modular design
- Simple operation

Machine type
 Inside width of machine in dm
 No. of screen cloths
 No. of vibrator poles
 No. of Divergators

F1026-D2

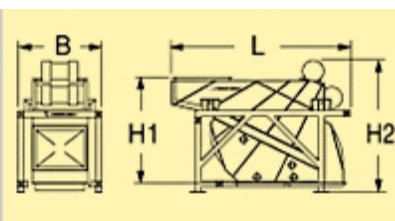

Type	Width	Length	Height 1	Height 2
F1006-D2	1735	3915	1750	2260
F1026-D2	1735	3915	2155	2665
F1506-D2	2210	3915	1750	2260
F1526-D2	2210	3915	2155	2665