

1400
space for screen-mat
changing

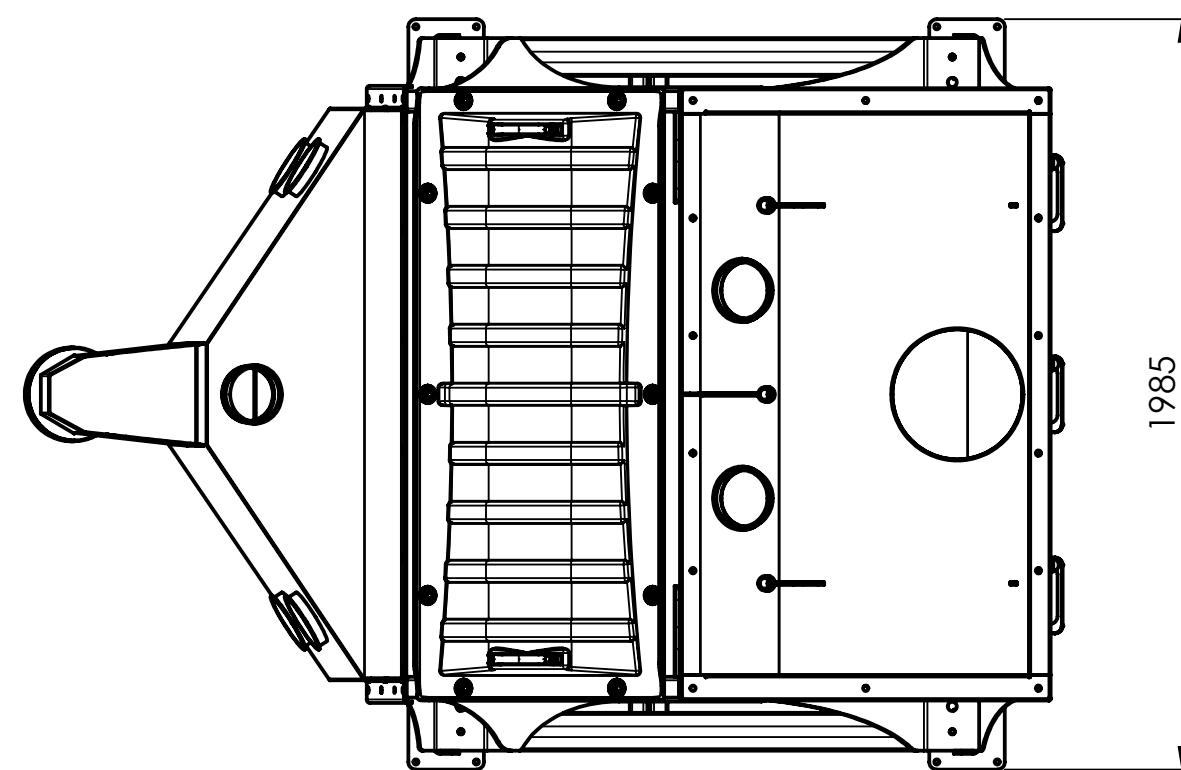
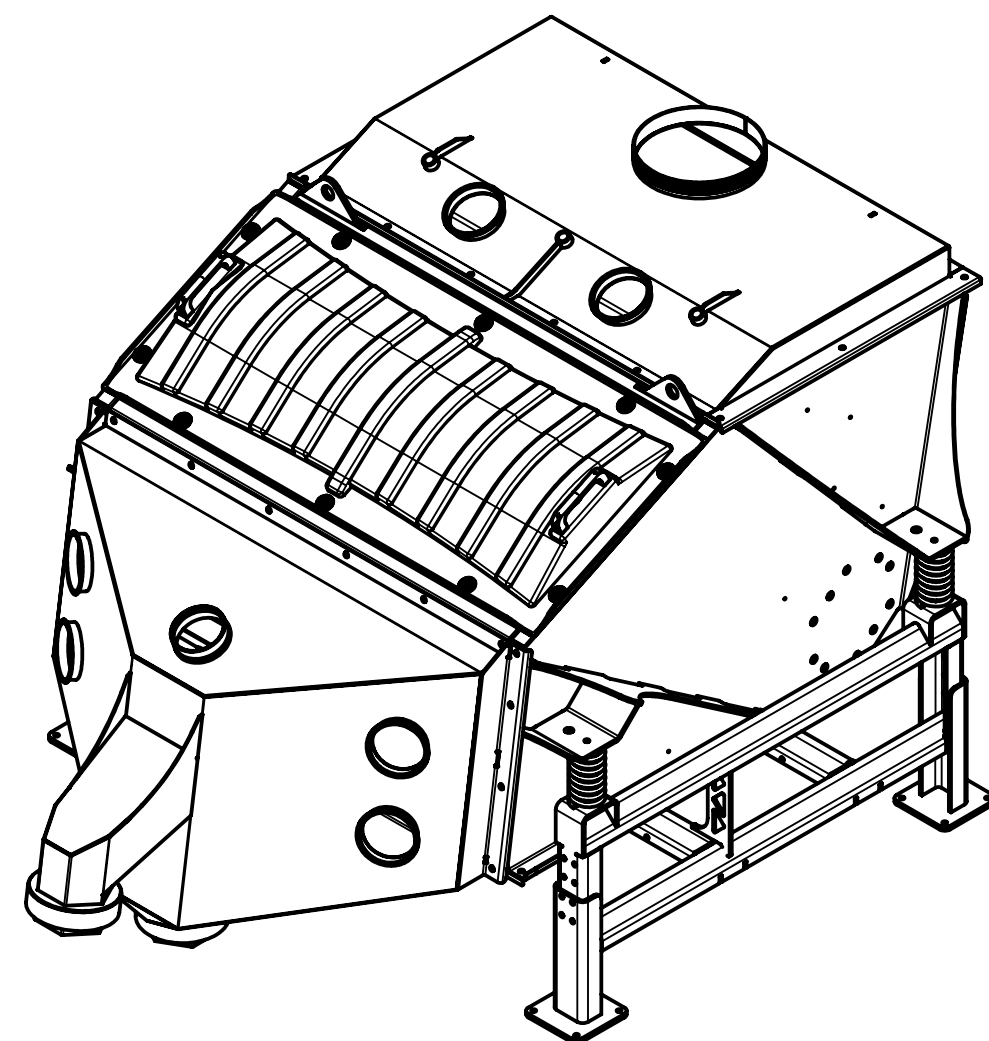
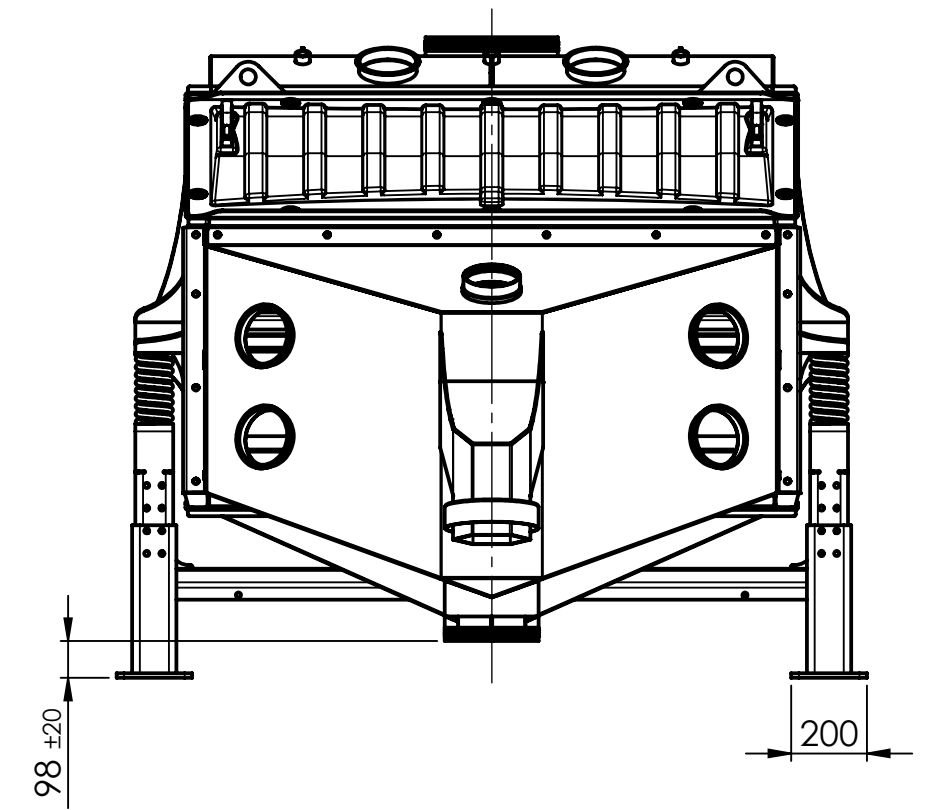
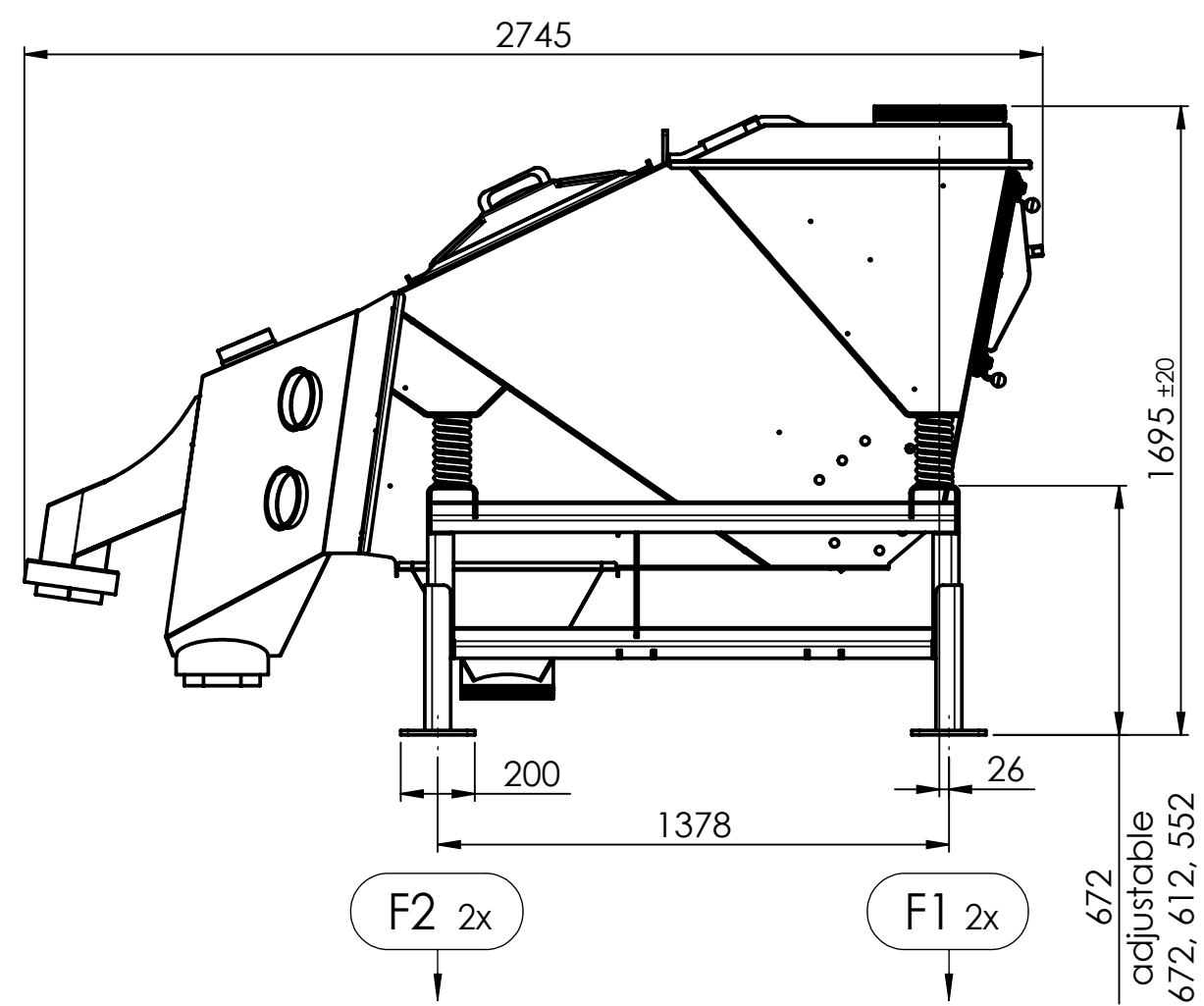

Inlet: Ø350
+1 Ø250
+2 Ø250
-2 Ø250

Förderichtung Conveying direction sans de manutention Verlagerungspunkte Supporting points Points de support		
F ₂	F ₁	F ₁
F ₂	F ₁	F ₁
Mindestabstand zu stationären Teilen 80 mm Minimum distance to stationary parts 80 mm Distance minimum aux éléments stationnaires 80 mm		
Betriebsbelastung Operation load Charge en service		
	stat. (N)	dyn. (N)
F ₁	v	3535 N
	h	± 165 N
F ₂	v	± 20 N
	h	± 20 N
Frequenz, Frequency, Frequence 24 Hz Gewicht, Weight, Poids ~ 1310 kg 1kp = 9,81 N 1N = 0,102 kp		

index	modification	date	name	index	modification	date	name																										
<table border="1"> <tr> <td>material</td> <td>date</td> <td>name</td> <td rowspan="3"> ALLGAIER PROCESS TECHNOLOGY Fredrik Mogensen AB Sveavägen 26 544 50 Hjo / Sweden www.allgaler-process-technology.com/en/fredrik-mogensen-ab </td> </tr> <tr> <td>weight (kg)</td> <td>scale</td> <td>drawn</td> </tr> <tr> <td>1029</td> <td>1:20</td> <td>checked</td> </tr> <tr> <td colspan="3"> description MSizer compact, C152x General drawing, for quotation only </td> <td>reference</td> </tr> <tr> <td colspan="3"> tolerances ISO 2768-mK ISO 13920 BE EN 20273-m </td> <td>compensation for</td> </tr> <tr> <td>part-no.</td> <td>drawing-no.</td> <td colspan="2">replaced by</td> </tr> <tr> <td colspan="3"></td> <td>page / of 1 / 1</td> </tr> </table>								material	date	name	ALLGAIER PROCESS TECHNOLOGY Fredrik Mogensen AB Sveavägen 26 544 50 Hjo / Sweden www.allgaler-process-technology.com/en/fredrik-mogensen-ab	weight (kg)	scale	drawn	1029	1:20	checked	description MSizer compact, C152x General drawing, for quotation only			reference	tolerances ISO 2768-mK ISO 13920 BE EN 20273-m			compensation for	part-no.	drawing-no.	replaced by					page / of 1 / 1
material	date	name	ALLGAIER PROCESS TECHNOLOGY Fredrik Mogensen AB Sveavägen 26 544 50 Hjo / Sweden www.allgaler-process-technology.com/en/fredrik-mogensen-ab																														
weight (kg)	scale	drawn																															
1029	1:20	checked																															
description MSizer compact, C152x General drawing, for quotation only			reference																														
tolerances ISO 2768-mK ISO 13920 BE EN 20273-m			compensation for																														
part-no.	drawing-no.	replaced by																															
			page / of 1 / 1																														

This drawing is not allowable for neither
 duplication nor accessible for any third
 party or competitor without our permission.